

IEL.N-H SOFT



Two-volume handles
with magnifying lens



SOFT

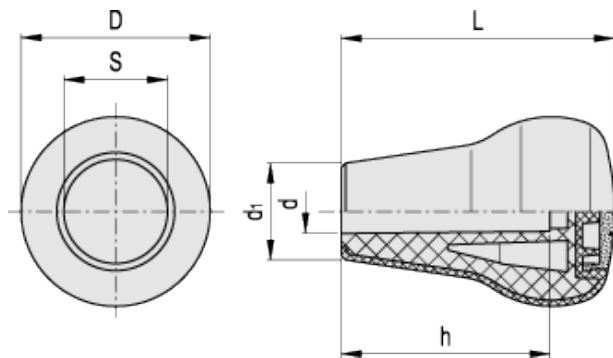

technical informations

Material

High-resilience polypropylene based (PP) technopolymer coated with "soft-touch" thermoplastic elastomer (TPE) chemically bonded, hardness 70 Shore A.

The coating material is certified in compliance with FDA (U.S. Food and Drug Administration).

Resistant to solvents, oils, greases and other chemical agents.

Colour

Black, matte finish.

Magnifying lens

Transparent polyamide based (PA-T) technopolymer. Resistant to solvents, oils, greases, petrol and other chemical agents (avoid contact with alcohol). Press-fit assembly. It improves the visibility of the labels.

Standard execution

Plain blind hole.

The elastic coupling by press-fit assembly on h9 tolerance drawn stock bars, is not affected by vibrations and prevents the handle from slipping off (see [Technical Data](#)).

Accessories on request

Self-adhesive labels [MA](#), with standard marks and symbols to be ordered separately.

Features and applications

The surface, coated with "soft-touch" elastomer, improves the grip even in the presence of oils, greases and sweat from the hand. For this reason it is suitable for fitness machines, tools and machines for gardening and goods transport, high-precision instruments and disability aids.

Assembly instructions

1. Fit the handle, without the magnifying lens, onto slight chamfered shaft end and push as far as possible by hand or by means of a small press. Alternatively it is possible to tap the handle with a plastic or wooden mallet until firmly in place. In this case we strongly recommend to use a cloth or other suitable soft material over the product to avoid any surface damage.
2. Stick the self-adhesive label (printed on the adhesive side) to the inner surface of the magnifying lens by pressing from the centre to the external side to avoid air bubbles. Assemble the magnifying lens to the handle face recess by gently tapping with a wooden or plastic mallet, until firmly in place. The label is therefore protected by the watertight magnifying lens.

Elesa Standards		Main dimensions				Mounting hole		Weight
Code	Description	L	D	d ₁	S	d	h	g
26672	IEL.65 N-10-H SOFT	65	45	23	25	10	50	56
26671	IEL.65 N-12-H SOFT	65	45	23	25	12	50	55



ELESA and GANTER models all rights reserved in accordance with the law. Always mention the source when reproducing our drawings.

STANDARD MACHINE ELEMENTS WORLDWIDE